

WOOD CHIPPER

User Manual

SAFETY AND OPERATION INSTRUCTIONS

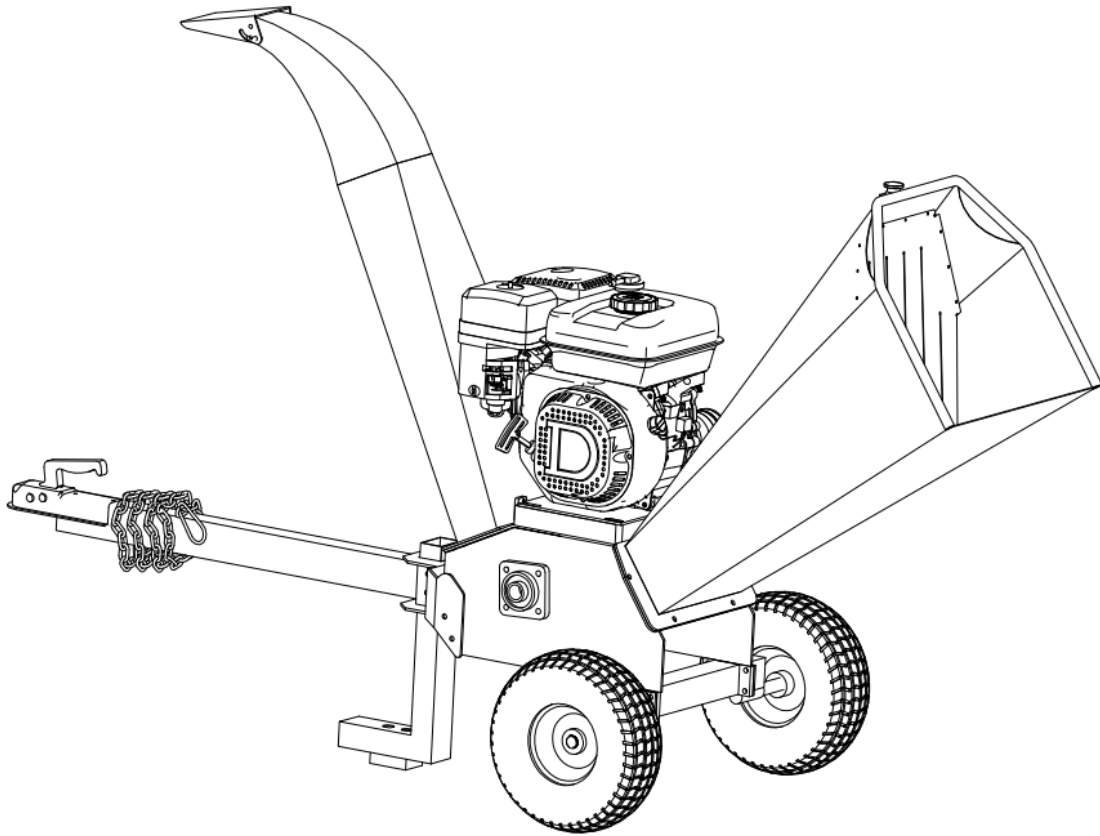

HC-1500EW

IMPORTANT: Read safety rules and instructions carefully before operating equipment.

Table of Contents

PART I: General Safety Rules	2
PART II: Familiar with the Wood Chipper.....	7
PART III: Operating the Wood Chipper	8
PART IV: Maintaining the Wood Chipper.....	10
PART V: Troubleshooting and Parts List	12

Conventions used in this manual

WARNING

This indicates a hazardous situation, which, if not avoided, could result in death or serious injury.

CAUTION

This indicates a hazardous situation, which, if not avoided, could result in minor or moderate injury.

NOTICE

This information is important in proper using of your machine. Failure to follow this instruction could result in damage to your machine or property.

Additional Information and Potential Changes

We reserve the right to discontinue, change, and improve its products at any time without notice or obligation to the purchaser. The descriptions and specifications contained in this manual were in effect at printing. Equipment described within this manual may be optional. Some illustrations may not be applicable to your machine.

PART I: General Safety Rules

Safety Labels Found on Your Unit



WARNING

Read this Safety & Operating Instructions manual before you use the Wood Chipper. Become familiar with the operation and service recommendations to ensure the best performance of your machine.

Propose

CAUTION

This machine is designed solely to chip wood and must not be used for any other purpose. It should only be used by trained operators who are familiar with the content of this manual. It is potentially hazardous to fit or use any parts other than your dealer parts. The company disclaims all liability for the consequences of such use, which in addition voids the machine warranty.

Before using the wood chipper

NOTICE

- A. Operators must be fully trained before using this machine.
 - B. User Manual is read and understood.
 - C. Machine is positioned on level ground, all guards are fitted and in good condition.
 - D. Blades are in good condition and secure. All blades are sharpened or replaced in sets.
 - E. All fasteners are checked for tightness.
 - F. Only WOODEN materials free of nails etc. are fed into the machine.
 - G. Fire extinguisher is available on site.
-

When using the wood chipper

NOTICE

- A. Always feed from the side.
 - B. It is better to have a second trained operator within easy reach of the machine.
 - C. Maintain strict discipline at all times and service machine at specified periods.
 - D. Note direction of discharge chute and if necessary note the wind direction to prevent debris from being blown into highway or where it could affect members of the public.
 - E. DO NOT put any part of your body into the in-feed chute while the machine is running.
 - F. DO NOT operate the machine whilst under the influence of alcohol or drugs.
 - G. DO NOT operate inside a building or confined space or Climb on the in-feed chute.
-

Protecting Yourself and Those Around You

WARNING

This is a high-powered machine, with moving parts operating with high energy. You must operate the machine safely. Unsafe operation can create a number of hazards for you, as well as anyone else in the nearby area. Always take the following precautions when using this machine:

- A. Keep in mind that the operator or user is responsible for accidents or hazards occurring to other people, their property, and themselves.
 - B. Always wear protective goggles or safety glasses with side shields while using the Wood Chipper to protect your eyes from possible thrown debris.
 - C. Avoid wearing loose clothing or jewelry, which can catch on moving parts.
 - D. We recommend wearing gloves while using the Wood Chipper. Be sure your gloves fit properly and do not have loose cuffs or drawstrings.
 - E. Wear shoes with non-slip treads when using your Wood Chipper. If you have safety shoes, we recommend wearing them. Do not use the machine while barefoot or wearing open sandals.
 - F. Wear long pants while operating the Wood Chipper.
 - G. Keep bystanders at least 50 feet away from your work area at all times. Stop the engine when another person or pet approaches.
-

Safety for Children and Pets

WARNING

Tragic accidents can occur if the operator is not alert to the presence of children and pets. Children are often attracted to the machine and the chipping activity. Never assume that children will remain where you last saw them. Always follow these precautions:

- A. Keep children and pets at least 50 feet from the working area and ensure they are under the watchful care of a responsible adult.
 - B. Be alert and turn the machine off if children or pets enter the work area.
 - C. Never allow children to operate the Wood Chipper.
-

Safety with Gasoline - Powered Machines

WARNING

Gasoline is a highly flammable liquid. Gasoline also gives off flammable vapor that can be easily ignited and cause a fire or explosion. Never overlook the hazards of gasoline. Always follow these precautions:

- A. Never run the engine in an enclosed area or without proper ventilation as the exhaust from the engine contains carbon monoxide, which is an odorless, tasteless, and a deadly poisonous gas.
 - B. Store all fuel and oil in containers specifically designed and approved for this purpose and keep away from heat and open flame, and out of the reach of children.
 - C. Replace rubber fuel lines and grommets when worn or damaged and after 5 years of use.
 - D. Fill the gasoline tank outdoors with the engine off and allow the engine to cool
-

completely. Don't handle gasoline if you or anyone nearby is smoking, or if you're near anything that could cause it to ignite or explode. Reinstall the fuel tank cap and fuel container cap securely.

- E. If you spill gasoline, do not attempt to start the engine. Move the machine away from the area of the spill and avoid creating any source of ignition until the gas vapors have dissipated. Wipe up any spilled fuel to prevent a fire hazard and properly dispose of the waste.
 - F. Allow the engine to cool completely before storing in any enclosure. Never store a machine that has gas in the tank, or a fuel container, near an open flame or spark such as a water heater, space heater, clothes dryer or furnace.
 - G. Never make adjustments or repairs with the engine running. Shut down the engine, disconnect the spark plug wire, keeping it away from the spark plug to prevent accidental starting, wait 5 minutes before making adjustments or repairs.
 - H. Never tamper with the engine's governor setting. The governor controls the maximum safe operation speed and protects the engine. Over-speeding the engine is dangerous and will cause damage to the engine and to the other moving parts of the machine. If required, see your authorized dealer for engine governor adjustments.
 - I. Keep combustible substances away from the engine when it is hot.
 - J. Never cover the machine while the muffler is still hot.
 - K. Do not operate the engine with the air cleaner or the carburetor air intake cover removed. Removal of such parts could create a fire hazard. Do not use flammable solutions to clean the air filter.
 - L. The muffler and engine become very hot and can cause a severe burn; do not touch.
-

General Safety

WARNING

Operating this Wood Chipper safely is necessary to prevent or minimize the risk of death or serious injury. Unsafe operation can create a number of hazards for you. Always take the following precautions when operating:

- A. Your Wood Chipper is a powerful tool, not a plaything. Exercise extreme caution at all times. The machine is designed to Chip Woods. Do not use it for any other purpose.
 - B. Know how to stop the Wood Chipper quickly.
 - C. Never operate your unit on a slippery, wet, muddy, or icy surface. Exercise caution to avoid slipping or falling.
 - D. See manufacturer's instructions for proper operation and installation of accessories.
 - E. Never use the machine without ensuring that all guards and shields are in place.
 - F. Never, under any conditions, remove, bend, cut, fit, weld, or otherwise alter standard parts on the Wood Chipper. This includes all shields and guards. Modifications to your machine could cause personal injuries and property damage and will invalidate your warranty.
 - G. If the machine start to make an unusual noise or vibrate, shut down the engine,
-

disconnect the spark plug wire, keeping it away from the spark plug to prevent accidental starting, wait 5 minutes for engine to cool down, then inspect for damage. Vibration is generally a warning of trouble. Check damaged parts and clean, repair and/or replace as necessary.

- H. Never tamper with safety devices. Check their proper operation regularly.
 - I. Before performing any maintenance or inspection procedure, shut down the engine, disconnect the spark plug wire keeping it away from the spark plug to prevent accidental starting, wait 5 minutes for machine to cool down.
 - J. Never allow people who are unfamiliar with these instructions to use the Wood Chipper. Allow only responsible individuals who are familiar with these rules of safe operation to use your machine.
 - K. Never overload or attempt to chip woods beyond the manufacturer's recommendation. It could result in personal injury or damage to the machine.
 - L. While using, don't hurry or take things for granted. When in doubt about the equipment or your surroundings stop the machine and take time to look things over.
 - M. Never operate the machine when under the influence of alcohol, drugs, or medication.
 - N. Use the machine only in daylight.
 - O. Stay alert for hidden hazards or traffic.
 - P. Keep all nuts and bolts tight and keep the equipment in good operating condition.
-

A Note to All Users

List of warnings and cautions cannot be all-inclusive. If situations occur that are not covered by this manual, the operator must apply common sense and operate this WOOD CHIPPER in a safe manner. Contact the dealers for assistance in your area.

PART II: Familiar with the Wood Chipper

It may be helpful to familiarize yourself with the controls and features of the Wood Chipper. If you have any question, please contact the dealers in your area.

TECHNICAL SPECIFICATIONS

	Recoil Start
Engine	11,0 kW four strokes, 410 cm³
Power	Gasoline/petrol
Chipper Capacity	4 CBM/hour
Wood Diameter	diameter 120 mm
Chipper Blade	twin reversible blades
Tire	6.5-8, 4.0-8, 4.8-8
Overall Height	1500 mm
Overall Length	1900 mm
Width	800mm
weight	185kgs
Roller Max RPM	2000

PART III: Operating the Wood Chipper

It may be helpful to better familiarize yourself with the features of your Wood Chipper before beginning the steps outlined in this chapter.

WARNING

- A. Read and understand all instructions, safety precautions, and/or warnings listed in “PART I: General Safety Rules” before operating the WOOD CHIPPER. If any doubt or question arises about the correct or safe method of performing anything found in this manual, please contact the dealers in your area.
 - B. When operating the Wood Chipper, make sure you are standing in the safe operating area (OPERATOR ZONE). You must stay in the safe operating area at all times when the ram is in motion (whether extending or retracting). Never place any part of your body into a position that causes an unsafe operating condition.
 - C. Before loading and operating the Wood Chipper, always wear protective gear, including safety goggles, hearing protection, tight-fitting gloves without draw strings or loose cuffs, and steel-toed shoes.
 - D. Knowing the correct and incorrect methods of Chipping woods. Never using an incorrect or unsafe method.
-

Starting

1. Position your Wood Chipper on flat, dry ground, and then stop the front wheel with brake, make sure the machine cannot be moved.
2. Make sure the fuel shut-off valve is in the “ON” position.
3. Move the choke control lever to the “CHOKE” position (should only be needed if the engine is cold).
4. Move the throttle control lever to the “FAST” position.
5. Recoil Start: Turn the Ignition Switch to the “On” position. Grasp the recoil starter handle and slowly pull until you feel resistance. Let the cord retract a little bit then pull the cord rapidly to start the engine. One or two pulls usually starts the engine.
6. Electric Start: Turn and hold the Key in the start position until Engine starts then let the Key return to run position.
7. Move the choke control lever (if used for cold engine) slowly back to the “RUN” position when the engine is running well.
8. If the Wood Chipper has not been running (cold engine), warm up the engine by running the engine at half throttle for 3 to 4 minutes, then advance the engine throttle control to the maximum speed.

Stopping

1. Move the Throttle Lever to IDLE.
2. Recoil Start: Turn the Ignition Switch to the OFF position.
3. Electric Start: Turn the Key to the OFF position.

Operator Zone

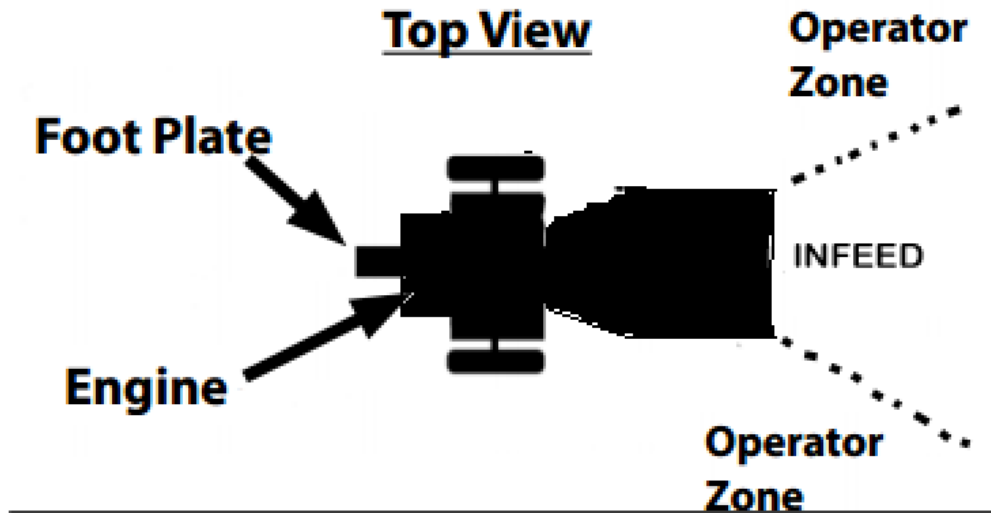

Wood Chipping

⚠ NOTICE

Woods' and branches' diameter should be no bigger than 120mm.

⚠ WARNING

Do not place your hands into the chute when loading. This is a very UNSAFE method and could result in injury to your hands.

Do not reach or step across the rail while the Wood Chipper is running. This is a very UNSAFE method which could cause personal injury, even death.

When Blocked

If the Roller stops while chipping woods or branches, the engine should be stopped, and take out the woods which stuck the roller, and then restart the engine, and chip again.

PART IV: Maintaining the Wood Chipper

Regular maintenance is the way to ensure the best performance and long life of your machine. Please refer to this manual and the engine manufacturer's user manual for maintenance procedures.

WARNING

Before performing any maintenance procedure or inspection, stop the engine, wait five minutes to allow all parts to cool. Disconnect the spark plug wire, keeping it away from the spark plug. Disconnect the Battery Terminals (Electric start only).

Regular Maintenance Checklist

Procedure	Before Each Use	Every 3 Hours	Every 25 Hours	Every 100 Hours
Check engine oil level	Δ			
Check general equipment condition	Δ			
Check wedge for sharpness	Δ			
Grease surface of slide rail	Δ			
Check belts	Δ			
Grease rack and pinion		Δ		
Check tire pressure			Δ	
Clean engine exterior and cooling			Δ	
Change Engine Oil	First time 5hours		Δ	
Replace air filter			Δ	
Replace spark plug				Δ

Engine Service

Refer to the engine manufacturer's user manual for engine maintenance.

Lubrication

NOTICE

All Bearings of your Chipper are sealed units and should have sufficient lubricant to last the life of your machine with normal use.

Greasing the rack and Pinion

NOTICE

All the rack and pinion should be greased before every use.

PART V: Troubleshooting and Parts List

Most problems are easy to fix. Consult the Troubleshooting Table below for common problems and their solutions. If you continue to experience problems, contact the dealers in your area.

WARNING

Before performing any maintenance procedure or inspection, stop the engine, wait five minutes to allow all parts to cool. Disconnect the spark plug wire, keeping it away from the spark plug.

Troubleshooting Table

SYMPTOM	POSSIBLE CAUSE
<p><i>The engine won't start.</i></p> <p><i>(Please refer to the engine user manual for engine-specific procedures.)</i></p>	<ul style="list-style-type: none"> ➤ <i>Is the ignition switch in the "ON" position?</i> ➤ <i>Is the fuel shut-off valve on?</i> ➤ <i>Are you using fresh, clean gas? If the gas is old, change it. Use a fuel stabilizer if you keep gas longer than 30 days.</i> ➤ <i>Is the spark plug clean? If the spark plug is dirty or cracked, change it. If it's oily, leave it out, hold a rag over the plug hole and pull the recoil cord several times to blow out any oil in the cylinder, then wipe off the plug and reinsert it.</i>
<p><i>The engine lacks power or is not running smoothly.</i></p> <p><i>(Please refer to the engine user manual for engine-specific procedures.)</i></p>	<ul style="list-style-type: none"> ➤ <i>Check that the Throttle Lever is in the "Run" position.</i> ➤ <i>Is the air filter clean? If it's dirty, change it following the procedure in the engine manufacturer's owner's manual.</i> ➤ <i>Is the spark plug clean? If it's fouled or cracked, change it. If it's oily, leave it out, hold a rag over the plug hole and pull your recoil cord several times to blow out any oil in the cylinder, then wipe off the plug and reinsert it.</i> ➤ <i>Are you using fresh, clean unleaded gas? If it's old, change it. Use a fuel stabilizer if you keep gas longer than 30 days.</i> ➤ <i>Does your engine have the right amount of clean oil? If it's dirty, change it following the procedure in the engine manufacturer's owner's manual.</i> ➤ <i>Check the oil level and adjust as needed.</i>
<p><i>Engine smokes.</i></p> <p><i>(Please refer to the engine user manual for engine-specific procedures.)</i></p>	<ul style="list-style-type: none"> ➤ <i>Check the oil level and adjust as needed.</i> ➤ <i>Check the air filter and clean or replace if needed.</i> ➤ <i>You may be using the wrong oil—too light for the temperature. Refer to your Engine Owner's Manual for detailed information.</i> ➤ <i>Clean the cooling fins if they're dirty.</i>

Part VI: Troubleshooting and Parts List

<p><i>Rack catching on tail tube (at end of stroke).</i></p> <p><i>Rack returning very slow or not going all the way back.</i></p>	<ul style="list-style-type: none"> ➤ <i>Adjust carriage hold downs (slide guides).</i> ➤ <i>Check for wood chips or debris between ram bushing plate and beam.</i> ➤ <i>Check rack lift bearing for alignment or damage.</i> ➤ <i>Return spring is unhooked or damaged. Reconnect or replace as needed.</i> ➤ <i>Machine wedge end too low. Must be almost level or wedge end slightly higher.</i>
<p><i>Operator Lever Snapping out of gear or not staying in gear.</i></p>	<ul style="list-style-type: none"> ➤ <i>Lever not all the way forward when rack comes under full load. Push lever quicker and more forcefully into the full forward position.</i> ➤ <i>Ram has been overloaded at lower part of face. Check rack gear for straightness.</i>
<p><i>Rack slamming back too fast.</i></p>	<ul style="list-style-type: none"> ➤ <i>Wedge end of machine too high. Must be almost level with ram end or just slightly higher.</i> ➤ <i>Springs not operating properly. Fix or replace as needed.</i>
<p><i>Machine does not seem to have full splitting power.</i></p>	<ul style="list-style-type: none"> ➤ <i>The belts may be too loose and slipping. Adjust or replace belts as needed.</i>
<p><i>Operator Lever not engaging rack with pinion gear.</i></p>	<ul style="list-style-type: none"> ➤ <i>Clean wood chips or other debris from under rack.</i> ➤ <i>Clean accumulated dirt from frame where carriage assembly rests against rubber bumpers.</i>

Explosion View

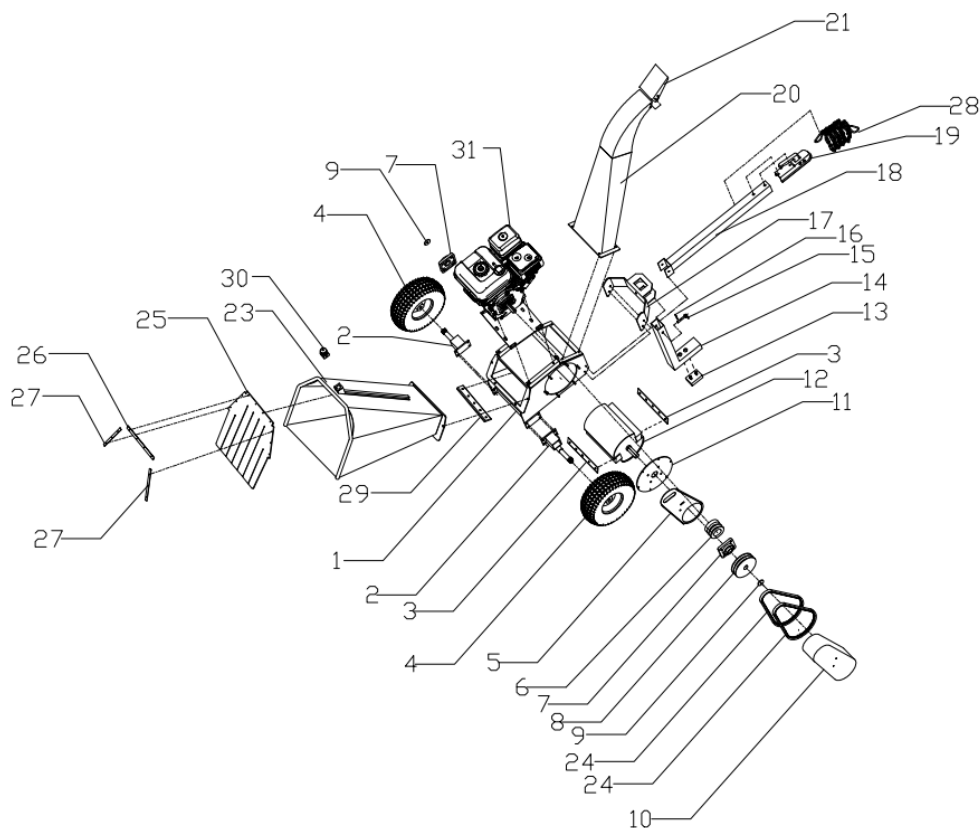

Ref.No.	Description	Ref.No.	Description
1	foundation	17	Feet fixation
2	Wheel axis	18	tower
3	Blade	19	Tower hitch
4	wheel	20	Discharge chute
5	Belt cover inner plate	21	Chute adjust
6	clutch	22	Engine fixation
7	bearing	23	In-feed
8	pulley	24	Belt
9	42*9*5 spacer	25	Rubber plate
10	Belt cover	26	Rubber fixation(upper)
11	Bearing fixation frame	27	Rubber fixation(side)
12	roller	28	chain
13	Rubber pad	29	Lower blade
14	Support feet	30	On/off switch
15	axis	31	Engine
16	Pin		